



## Onboard kitchens and accessories



# TM Company



## TM – Company

---

The owner-run family business **TM** Technischer Gerätebau GmbH was originally developed from an electrical wholesalers which still exists to this day. The company, which was officially launched by Hermann Fixl in 1991, started off by constructing cool boxes for the automotive industry and developed into what it is today. **TM** has its headquarters in Neu-Ulm and is now run by the fourth generation of the founding family.



## TM – Specialist

---

Known as a refrigeration and small-scale assembly specialist, **TM** perfectly serves its niche markets in particular. Product solutions are designed and implemented in-house and independently or manufactured according to the customer's detailed specifications.



Our products are used in mobile as well as static installations. Speed, flexibility and many years of experience in manufacturing and development make the company a strong and reliable partner in the industry.

## TM – Products

---

Since its founding, **TM** has been producing components for mobile passenger services, mainly used in buses as well as in trucks and rail vehicles. **TM** has developed product solutions for a wide range of applications over the years and has firmly established itself in a wide range of industries such as, for example, in the field of fully automatic coffee machines.

The wide-ranging product portfolio includes the classic dashboard cool box, board kitchens and toilets for the bus industry as well as milk coolers for coffee machines, and many more.



## TM – International

In 2007, **TM** established a subsidiary company near Istanbul to respond to increasing globalisation and the integration of markets. **TM-Turkey** mainly operates in the expanding bus and truck sector in its home market, as well as in neighbouring Arab countries.

In the same year, **Jincen-TM** was established as a joint venture company in China's Anhui Province to serve the Chinese market and to create more synergies. The Chinese company is mainly focused on producing injection moulded parts for the automotive, electrical and household industries as well as assembling on-board kitchens and cool boxes.

Being close to our customers and quick response times are of paramount importance for **TM** so our customers can rely on a Europe-wide network of service partners. **TM** can guarantee a seamless and fast on-site service through the continuous expansion of our partners.



## TM – Philosophy

**TM Technischer Gerätebau GmbH** is a family-run business, distinguished by our short and direct lines of communication, as well as continuity.

From product design, through quality assurance of the materials used, right up to the final product test, we place the highest value on the perfect processing and precision of our products. Naturally, our products are certified according to relevant EU directives as well as our quality management system being certified according to ISO guidelines.

## TM – Customer satisfaction

Innovative concepts to a high technical standard, together with excellent materials and processing quality, create outstanding products. Our product solutions are constantly setting new standards due to their functionality, compact dimensions and attractive design.

Experience, reliability, quality and long-term success are the building blocks of the current product range and the foundation for satisfied customers throughout the world.





# On the way home



## **TM onboard kitchens**

We have a wide variety of onboard kitchens for you to choose from.  
We are happy to advise you – ask our specialists!

# Onboard kitchen available over-the-counter

## QuickService MultiPlus 2G

A real highlight that sets standards. Perfect functions and modern design with sophisticated solutions.

As an innovative manufacturer of onboard kitchen systems, we specialise in the development and manufacture of high-quality onboard kitchens for modern passenger services. Using modular designs, we can adapt onboard kitchen furnishings to the needs of our customers. Straightforward usability makes our onboard kitchens particularly easy to service.

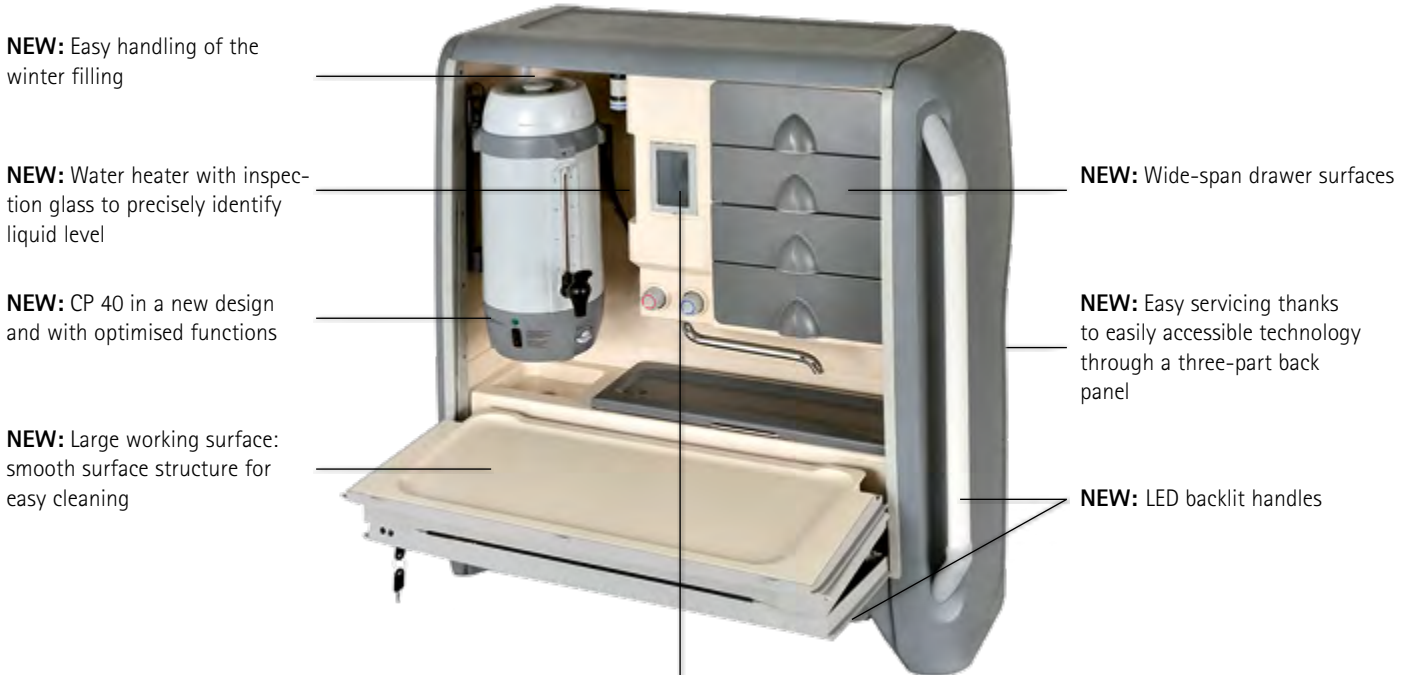

**NEW:** Easy handling of the winter filling

**NEW:** Water heater with inspection glass to precisely identify liquid level

**NEW:** CP 40 in a new design and with optimised functions

**NEW:** Large working surface: smooth surface structure for easy cleaning

**NEW:** Wide-span drawer surfaces

**NEW:** Easy servicing thanks to easily accessible technology through a three-part back panel

**NEW:** LED backlit handles

**NEW:** Touch panel – navigate through the menu with symbols, written explanations and visual function bars



selectable between German and English language

start screen can be customised using an SD card

reset function

multi-level pin code protection

LED illumination control function

water heater filling

control of water heater thermostat

control of sausage cooker

swipe-action water heater adjustment

display for heating function and error messages

# Onboard kitchen available over-the-counter

New customised design and state-of-the-art technology.

The QuickService MultiPlus 2G is an upgrade of our tried and tested QuickService MultiPlus onboard kitchen. The technology and design language are adapted to the needs and trends of the coach industry.

Plastic films are used to adapt the colour scheme of the housing to customer specifications. A three-part back panel allows faster service and maintenance. Folding tables are recessed in the back wall. Customer-specific solutions can also be developed for bus manufacturers. Backlit handles provide additional safety. New materials have reduced the weight. The onboard kitchen can be easily operated using the new touch panel.

## QS MultiPlus 2G with CP 40

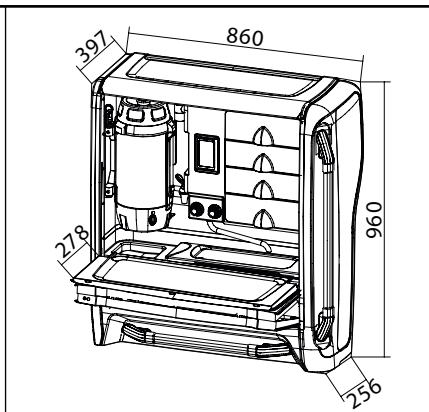

**order no.:**

05.3090.00.00

**coffee maker**

**CP 40:** 5 l 700 W – 30,0 A

**water heater:** 5 l 500 W – 21,0 A

**sausage cooker:** 8,5 l 500 W – 21,0 A

**voltage:** 24 V DC

**weight:** 49 kg

**casing:** PVC film with grey foam backing, finely grained, work flap and front flaps with ABS and lock

**options:**

Vehicle-specific installation kit on request

**scope of delivery:**

- 5-liter CaféPerfect 40 coffee maker
- 5-liter water heater
- 8,5-liter WK 500 sausage cooker with overflow pipe
- touch panel for LED illumination function, thermostat, boiler filling and display for heating function and error messages, reset function to protect against overheating
- 2 drawers large, 2 drawers short
- drain basin
- water tap for filling the coffee maker
- rear side: 2 tables, luggage net

Additional extras for CaféPerfect under the accessories category.

Swing-out and lockable coffee machine holder.

For more information see the QuickService MultiPlus 2G instruction manual.

Front: closed

Rear side: 2 recessed folding tables, large net



# Onboard kitchen available over-the-counter

## QS MultiPlus 2G with vacuum jug

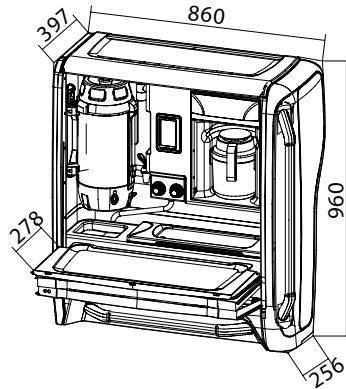

**order no.:**

05.3091.00.00

**coffee maker**

**CP 40:** 5 l 700 W – 30,0 A

**water heater:** 5 l 500 W – 21,0 A

**sausage cooker:** 8,5 l 500 W – 21,0 A

**vacuum jug:** 1,3 l

**voltage:** 24 V DC

**weight:** 50 kg

**casing:** PVC film with grey foam backing, finely grained, work flap and front flaps with ABS and lock

**options:**

Vehicle-specific installation kit on request

QuickService MultiPlus 2G with vacuum jug.

Other features same as 05.3090.00.00.

## QS MultiPlus 2G with two CP 40

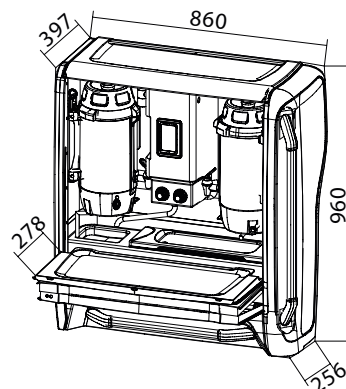

**order no.:**

05.3092.00.00

**coffee maker**

**CP 40 2x:** 5 l 700 W – 30,0 A

**water heater:** 5 l 500 W – 21,0 A

**sausage cooker:** 8,5 l 500 W – 21,0 A

**voltage:** 24 V DC

**weight:** 53 kg

**casing:** PVC film with grey foam backing, finely grained, work flap and front flaps with ABS and lock

**options:**

Vehicle-specific installation kit on request

QuickService MultiPlus 2G with two CaféPerfect 40.

Other features same as 05.3090.00.00.

QuickService MultiPlus 2G kitchens meet the following guidelines and certifications:

- EMC Directive ECE R10
- Fire behaviour per regulation ECE R118.03 annex 6 + 8
- Head impact testing ECE R21 annex 4
- GBK type testing



# Onboard kitchen available over-the-counter

## QuickService Duo with 4 components

A practical 4-in-1 solution for comprehensive passenger service that leaves nothing to be desired.

The QuickService Duo with 4 components is equipped with a 35-litre cool box. In addition to a 5-litre sausage cooker, it also has a CaféPerfect 40 and a water heater.

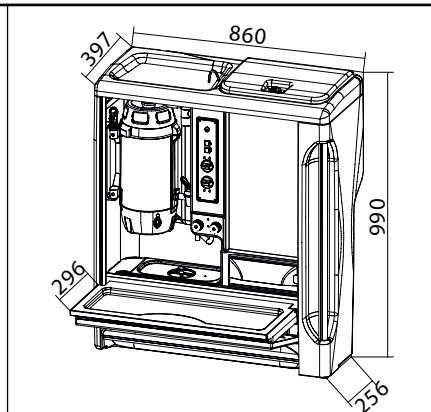

## QS Duo with 4 components

**order no.:**

05.4224.00.00

**cool box:** 35 l 54 W – 2,3 A

**Refrigerant:** R600A

**coffee maker**

**CP 40:** 5 l 700 W – 30,0 A

**water heater:** 5 l 600 W – 25,0 A

**sausage cooker:** 5 l 500 W – 21,0 A

**voltage:** 24 V DC

**weight:** 64 kg

**casing:** foamed with PU integral, semi-hard foam in dark grey, finely grained, work flap and front flaps with ABS and lock

**scope of delivery:**

- 5-liter CaféPerfect 40 coffee maker
- 35-liter cool box, insulating PU foam
- 5-liter water heater
- 5-liter WK 181 sausage cooker
- top loader, lockable cover
- control panel for thermostat, light, function indicator and fuse protection for electronics
- rear side: 2 tables, luggage net, ashtray optional

The QuickService Duo with 4 components kitchen meets the following guidelines and certifications:

- EMC Directive ECE R10
- Fire behaviour per regulation ECE R118.01 annex 6
- GBK type testing

**options:**

Vehicle-specific installation kit on request

Additional extras for CaféPerfect under the accessories category.

Front: closed



Rear side: 2 recessed folding tables, large net



35-liter cool box



# Onboard kitchen available over-the-counter

## QuickService Multi Plus 2G Duo

The economic alternative for simple passenger service.

QuickService Multi Plus 2G Duo is equipped with a 55-litre cool box and a 5-litre water heater.

### QS Multi Plus 2G Duo

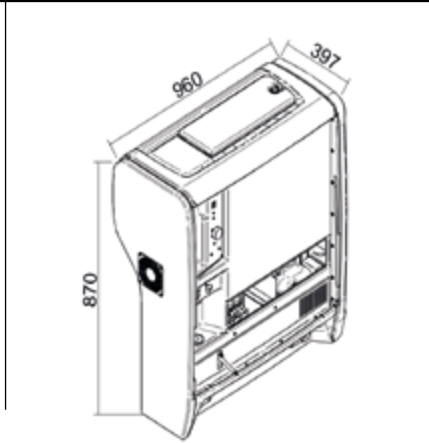

**order no.:**

05.9020.00.00

**cool box:** 55 l 60 W – 3 A

**water heater:** 5 l 600 W – 25 A

**voltage:** 24 V DC

**weight:** 65 kg

**casing:** foamed with PU integral,  
semi-hard foam in dark grey,  
finely grained, lockable cover  
optional

**options:**

Vehicle-specific installation kit on request

**scope of delivery:**

- 55-liter cool box, insulating PU foam with foam-fixed conveyor evaporator
- 5-liter water heater, insulating PU foam with mongrel fitting and discharge port, reset function to protect against overheating
- top loader, lockable cover
- control panel for thermostat, light in refrigerator, function indicator and fuse protection for electronics
- drain basin
- cup dispenser
- rear side: 2 tables, luggage net, ashtray optional

QuickService Duo kitchens meet the following guidelines and certifications:

- EMC Directive ECE R10
- Fire behaviour per regulation ECE R118.01 annex 6
- Head impact testing 2000/4 EG
- GBK type testing

# Onboard kitchen available over-the-counter

## QuickService Concept

The lightweight with compact outer dimensions.

The QuickService Concept is the perfect addition to our QuickService onboard kitchen series. Its compact external dimensions and two options for variation thanks to the modular design make this onboard kitchen a real alternative for passenger service in any class.

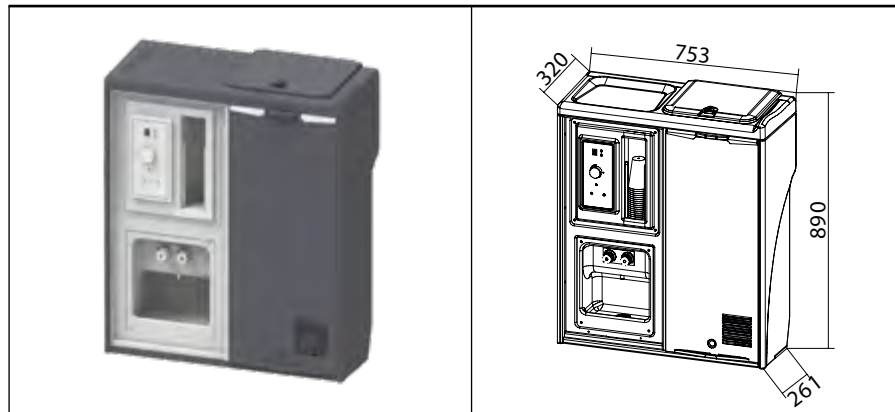

## QS Concept with water heater

**order no.:**

05.4030.00.00

**cool box:** 40 l 54 W – 2,3 A

**water heater:** 5 l 600 W – 25,0 A

**voltage:** 24 V DC

**weight:** 43 kg

**casing:** PVC film with grey foam backing,  
finely grained, lockable cover  
optional

**options:**

Vehicle-specific installation kit on request

**scope of delivery:**

- 40-liter cool box, insulating PU foam with foam-fixed conveyor evaporator
- 5-liter water heater, insulating PU foam with mongrel fitting and discharge port, reset function to protect against overheating
- top loader, lockable cover
- control panel for thermostat, light in refrigerator, function indicator and fuse protection for electronics
- drain basin
- cup dispenser
- rear side: table, luggage net, 2 cupholders

# Onboard kitchen available over-the-counter

## QS Concept with CP 40

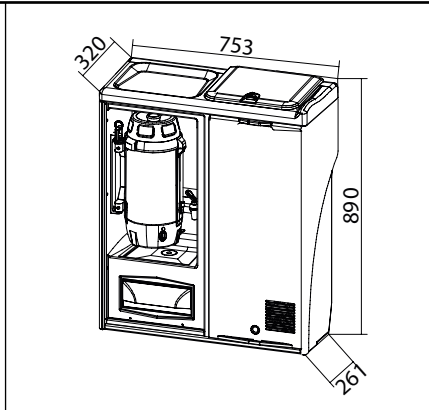

**order no.:**

05.4035.00.00

**cool box:** 40 l 54 W – 2,3 A

**coffee maker**

**CP 40:** 5 l 700 W – 30,0 A

**voltage:** 24 V DC

**weight:** 43 kg

**casing:** PVC film with grey foam backing, finely grained, lockable cover optional

**options:**

Vehicle-specific installation kit on request

**scope of delivery:**

- 5-liter CaféPerfect 40 coffee maker
- 40-liter cool box, insulating PU foam with foam-fixed conveyor evaporator
- top loader, lockable cover
- control panel for thermostat, light in refrigerator, function indicator and fuse protection for electronics
- drain basin
- drawer
- rear side: table, luggage net, 2 cupholders

Additional extras for CaféPerfect under the accessories category.

Optional for QuickService Concept:

lockable cover with lock, order no.: 52.4020.02.11



QuickService Concept kitchens meet the following guidelines and certifications:

- EMC Directive ECE R10
- Fire behaviour per regulation ECE R118.01 annex 6
- Head impact testing 2000/4 EG

# Onboard kitchen available over-the-counter

## QuickService Domino

The attractive complement for going the extra mile in passenger service.

Three ideal solutions to meet the requirements of the service sector. With its diverse range of hot drink options, QuickService Domino is an ideal addition in any onboard kitchen. Due to the narrow column construction which is just 41cm wide, QuickService Domino is particularly suitable for installation next to the tour guide's seat. QuickService Domino can even fit in minibuses and midibuses.

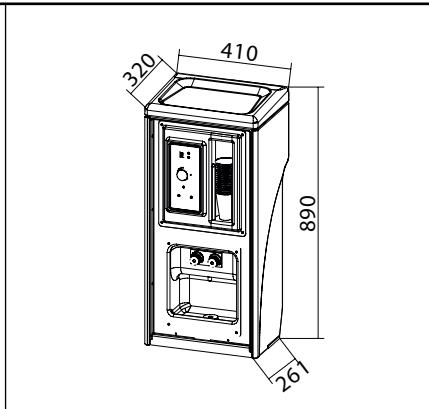

### scope of delivery:

- 5-liter water heater, insulating PU foam with mongrel fitting and discharge port, reset function to protect against overheating
- drain basin
- cup dispenser
- rear side: luggage net, cupholder

### QS Domino with water heater

#### order no.:

05.5030.00.00

<b>water heater:</b>	5 l	600 W - 25,0 A
<b>voltage:</b>	24 V DC	
<b>weight:</b>	20 kg	
<b>casing:</b>	PVC film with grey foam backing, finely grained, lockable cover optional	

#### options:

Vehicle-specific installation kit on request

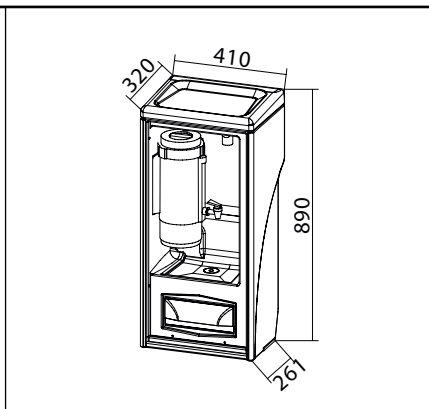

### scope of delivery:

- 2,5-liter CaféPerfect 20 coffee maker, swing-out holder in stainless steel
- drawer
- rear side: luggage net, cupholder

Additional extras for CaféPerfect under the accessories category.

### QS Domino with CP 20

#### order no.:

05.5032.12.00 (12 V)

#### coffee maker

<b>CP 20:</b>	2,5 l	400 W - 35,0 A
<b>voltage:</b>	12 V DC	
<b>weight:</b>	19 kg	
<b>casing:</b>	PVC film with grey foam backing, finely grained, lockable cover optional	

#### order no.:

05.5032.00.00 (24 V)

#### coffee maker

<b>CP 20:</b>	2,5 l	500 W - 21,0 A
<b>voltage:</b>	24 V DC	
<b>weight:</b>	19 kg	
<b>casing:</b>	PVC film with grey foam backing, finely grained, lockable cover optional	

#### options:

Vehicle-specific installation kit on request

## QS Domino with CP 40

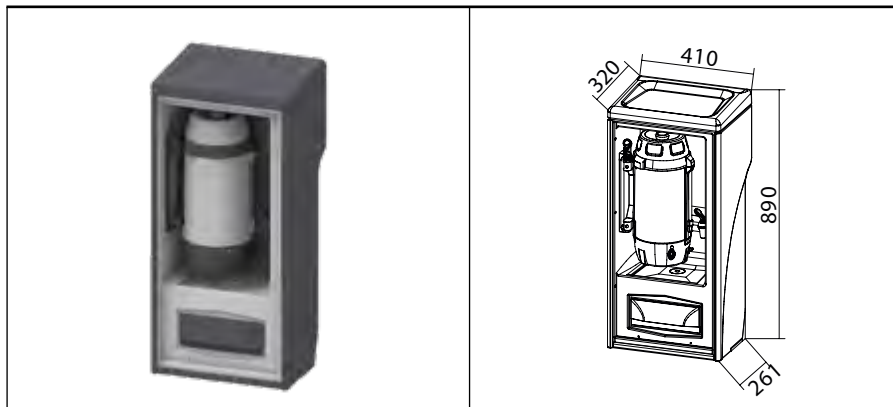

**order no.:**  
05.5035.00.00

<b>coffee maker</b>		
<b>CP 40:</b>	5 l	700 W – 30,0 A
<b>voltage:</b>	24 V DC	
<b>weight:</b>	20 kg	
<b>casing:</b>	PVC film with grey foam backing, finely grained, lockable cover optional	

**scope of delivery:**

- 5-liter CaféPerfect 40 coffee maker, lockable plastic holder
- drawer
- rear side: luggage net, cupholder

**options:**

Vehicle-specific installation kit on request

Optional for QuickService Domino:  
lockable cover with lock, order no.: 52.4020.02.11



QuickService Domino kitchens meet the following guidelines and certifications:

- EMC Directive ECE R10
- Fire behaviour per regulation ECE R118.01 annex 6

# Onboard kitchen available over-the-counter

## QuickService Micro

The narrow version for when there's a little less space in the coach.

QuickService Micro is distinguished by its compact dimensions. The system is suitable for mid-size buses, minibuses and more.

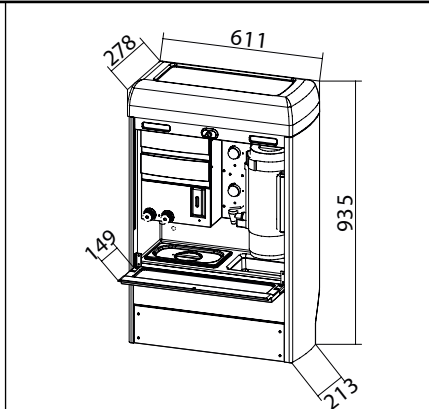

### scope of delivery:

- 2,5-liter CaféPerfect 20 coffee maker
- 3-liter water heater with thermostat knob, reset function to protect against overheating, LED-indicator for heating and error messages inspection glass
- 5-liter WK 160/161 sausage cooker with overflow pipe
- control panel for sausage cooker and water heater, interior light
- 2 drawers short

- water tap for filling the coffee maker
- drain basin
- switch for water pump
- rear side: luggage net

Version with priority switching, electronic, only two devices can be operated at the same time. The CaféPerfect 20 coffee maker always takes priority.

Additional extras for CaféPerfect under the accessories category.

## QS Micro

### order no.:

05.9012.00.00 (12 V)

### coffee maker

**CP 20:** 2,5 l 400 W – 35,0 A

**water heater:** 3 l 300 W – 25,0 A

**sausage cooker:** 5 l 300 W – 25,0 A

**voltage:** 12 V DC

**weight:** 40 kg

**casing:** cover, rear side and side panel right with ABS aero grey, service flap, cover, cover for technical area and side panel left MDF lacquering

### order no.:

05.9024.00.00 (24 V)

### coffee maker

**CP 20:** 2,5 l 500 W – 21,0 A

**water heater:** 3 l 500 W – 21,0 A

**sausage cooker:** 5 l 500 W – 21,0 A

**voltage:** 24 V DC

**weight:** 40 kg

**casing:** see above

QuickService Micro kitchen meet the following guidelines and certifications:

- EMC Directive ECE R10
- Head impact testing 2000 / 4 EG
- GBK type testing

## QS Micro 2

### order no.:

05.9030.00.00

### coffee maker

**CP 40:** 5 l 700 W – 30,0 A

**water heater:** 5 l 500 W – 21,0 A

**sausage heater:** 5 l 500 W – 21,0 A

**voltage:** 24 V DC

**weight:** 31 kg

**casing:** wooden laminated, front service flap with ABS

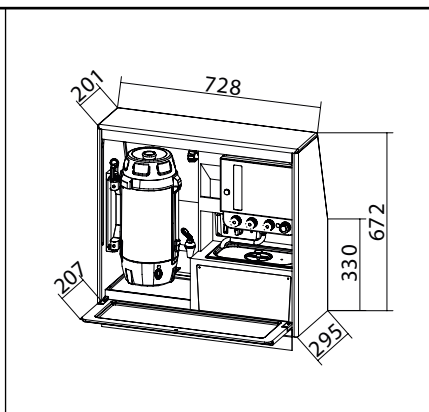

### scope of delivery:

- 5-liter CaféPerfect 40 coffee maker
- 5-liter water heater with thermostat knob, reset function to protect against overheating, inspection glass
- 5-liter WK 160/161 sausage cooker with overflow pipe
- water tap for filling the coffee maker
- drain basin
- switch for water pump
- rear side: no other equipment

QuickService Micro 2 kitchen meet the following guidelines and certifications:

- EMC Directive ECE R10
- GBK type testing

# Onboard kitchen available over-the-counter

## QuickService TAK

The variant which requires hardly any space.

With its small outer dimensions, QuickService TAK is ideally suited for buses with limited space. It can, for example, be placed directly above the bus toilet.

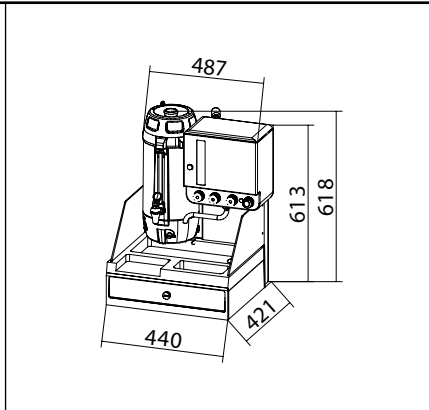

### QS TAK with CP 40 and VEK 6

**order no.:**

05.8800.00.00

**coffee maker**

**CP 40:** 5 l 700 W – 30,0 A

**water heater:** 5 l 500 W – 21,0 A

**voltage:** 24 V DC

**weight:** 18 kg

**casing:** PUR anthracite structure, lacquering, made with RTM technology, rear metal plate, powder-coated, side panel of clear acrylic

**scope of delivery:**

- 5-liter CaféPerfect 40 coffee maker
- 5-liter VEK 6 water heater with descaling opening, reset function to protect against overheating
- drawer
- water tap for filling the coffee maker
- storage area
- rear side: no other equipment

Additional extras for CaféPerfect under the accessories category.

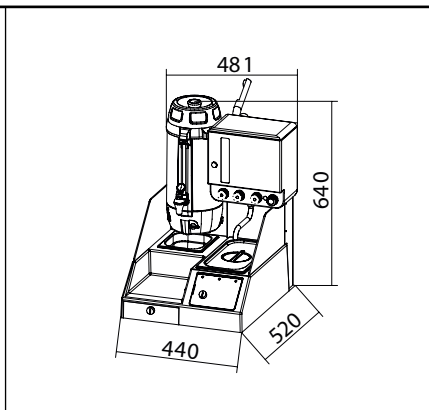

### QS TAK

**order no.:**

05.8300.00.00

**coffee maker**

**CP 40:** 5 l 700 W – 30,0 A

**water heater:** 5 l 500 W – 21,0 A

**sausage cooker:** 5 l 500 W – 21,0 A

**voltage:** 24 V DC

**weight:** 19 kg

**casing:** PUR anthracite structure, lacquering, made with RTM technology, rear metal plate, powder-coated, side panel of clear acrylic

**scope of delivery:**

- 5-liter CaféPerfect 40 coffee maker
- 5-liter VEK 6 water heater with descaling opening, reset function to protect against overheating
- 5-liter WK 121 sausage cooker with overflow pipe
- control panel, thermostat knob and optical indicator for heating and error messages
- water tap for filling the coffee maker
- drain basin
- storage area
- rear side: no other equipment

QuickService TAK kitchens meet the following guidelines and certifications:

- EMC Directive ECE R10



# Onboard kitchen available over-the-counter

## QuickService TAM

The little sister of TAK.

QuickService TAM is only half the size of QuickService TAK and is thus the most space-saving of our on-board kitchens.

## QS TAM

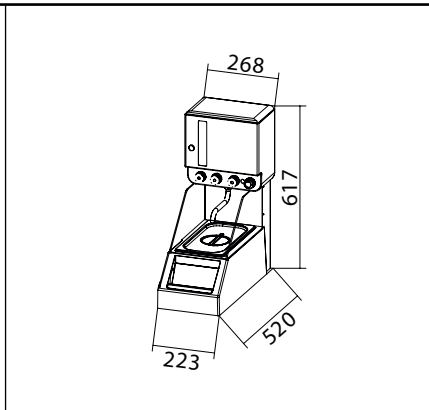

### order no.:

05.8301.00.00

**water heater:** 5 l 500 W - 21,0 A

**discharge basin:** 5 l

**voltage:** 24 V DC

**weight:** 12 kg

**casing:** PUR anthracite structure, lacquering, made with RTM technology, rear metal plate, powder-coated, side panel of clear acrylic

### scope of delivery:

- 5-liter VEK 6 water heater with descaling opening, reset function to protect against overheating
- drain basin
- rear side: no other equipment

# Onboard kitchen customer-specific

## QuickService MultiPlus 2G EvoBus

The QuickService MultiPlus 2G EvoBus is an upgrade of our tried and tested QuickService MultiPlus EvoBus onboard kitchen. The technology and design language are adapted to the needs and trends of the coach industry.

Plastic films are used to adapt the colour scheme of the housing to customer specifications. A three-part back panel allows faster service and maintenance. Folding tables are recessed in the back wall. Customer-specific solutions can also be developed for bus manufacturers. Backlit handles provide additional safety. New materials have reduced the weight. The onboard kitchen can be easily operated using the new touch panel.

### QS MultiPlus 2G EvoBus with CP 40

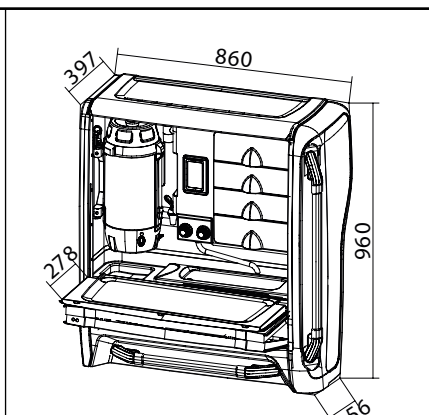

<b>order no.:</b>		
05.4290.00.00		
<b>coffee maker</b>		
<b>CP 40:</b>	5 l	700 W – 30,0 A
<b>water heater:</b>	5 l	500 W – 21,0 A
<b>sausage cooker:</b>	8,5 l	500 W – 21,0 A
<b>voltage:</b>	24 V DC	
<b>weight:</b>	49 kg	
<b>casing:</b>	PVC film with dark grey foam backing, finely grained, work flap and front flaps with ABS and lock	

#### scope of delivery:

- 5-liter CaféPerfect 40 coffee maker
- 5-liter water heater
- 8,5-liter WK 500 sausage cooker with overflow pipe
- touch panel for LED illumination function, thermostat, boiler filling and display for heating function and error messages, reset function to protect against overheating
- 2 drawers large, 2 drawers short
- drain basin
- water tap for filling the coffee maker
- rear side: 2 tables, luggage net

### QS MultiPlus 2G EvoBus with vacuum jug

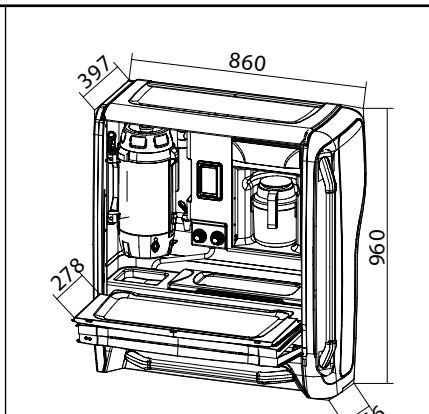

<b>order no.:</b>		
05.4291.00.00		
<b>coffee maker</b>		
<b>CP 40:</b>	5 l	700 W – 30,0 A
<b>water heater:</b>	5 l	500 W – 21,0 A
<b>sausage cooker:</b>	8,5 l	500 W – 21,0 A
<b>vacuum jug:</b>	1,3 l	
<b>voltage:</b>	24 V DC	
<b>weight:</b>	50 kg	
<b>casing:</b>	PVC film with dark grey foam backing, finely grained, work flap and front flaps with ABS and lock	

Additional extras for CaféPerfect under the accessories category.

## QS MultiPlus 2G EvoBus with two CP 40

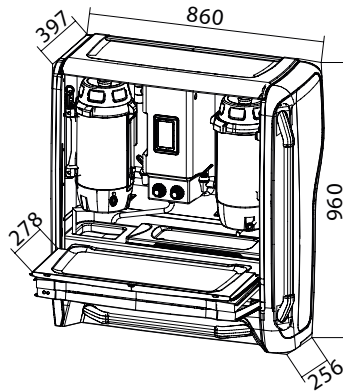

**order no.:**

05.4092.00.00

**coffee maker**

**CP 40:** 5 l 700 W – 30,0 A

**water heater:** 5 l 600 W – 25,0 A

**sausage cooker:** 8,5 l 600 W – 25,0 A

**voltage:** 24 V DC

**weight:** 61 kg

**casing:** PVC film with dark grey foam backing, finely grained, work flap and front flaps with ABS and lock

QuickService MultiPlus 2G EvoBus kitchens meet the following guidelines and certifications:

- EMC Directive ECE R10
- Fire behaviour per regulation ECE R118.03 annex 6 + 8
- Head impact testing ECE R21 annex 4
- GBK type testing

## Rear onboard kitchen narrow

A perfect solution for installation in the tail of the bus.

The rear onboard kitchen is distinguished by its pleasant working height and clear structure.

## Rear onboard kitchen narrow

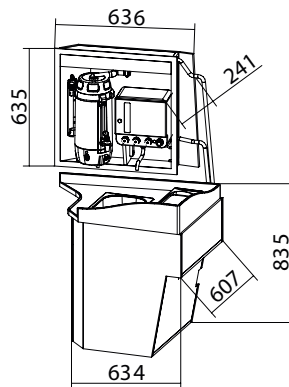

**order no.:**

05.8901.00.00

**coffee maker**

**CP 40:** 5 l 700 W – 30,0 A

**water heater:** 5 l 500 W – 21,0 A

**sausage cooker:** 8,5 l 600 W – 25,0 A

**voltage:** 24 V DC

**weight:** 61 kg

**casing:** solid wooden case, lacquering according to customer requirements

**scope of delivery:**

- 5-liter CaféPerfect 40 coffee maker
- 5-liter VEK 6 water heater with descaling opening, reset function to protect against overheating
- 8.5-liter WK 500 sausage cooker with overflow pipe, reset function to protect against overheating, thermostat knob and optical indicator for heating and error messages
- control panel, water supply and drain basin
- water tap for filling the coffee maker
- Storage area
- Rear side: no other equipment
- The Rear onboard kitchen narrow meets the following guidelines and certifications: EMC Directive ECE R10

Additional extras for CaféPerfect under the accessories category.

# Onboard kitchen customer-specific

## QuickService MultiPlus NEOPLAN/MAN

The onboard kitchen for NEOPLAN and MAN vehicles.

QuickService MultiPlus for NEOPLAN / MAN is available with a modular design and in several configurations. The housing can be customised according to customer requirements. In addition, this galley kitchen stands out in particular thanks to its straight-forward usability.

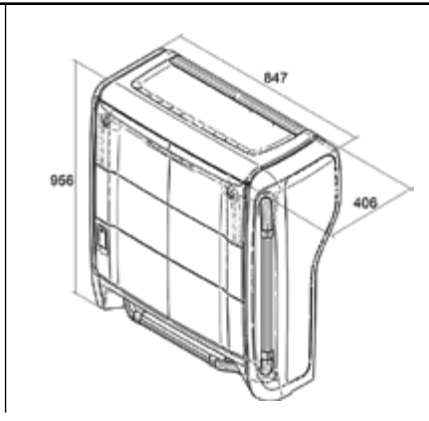

### QS MultiPlus MAN

**order no.:**

05.6090.00.00	
05.6091.00.00	options: with vacuum jup
05.6092.00.00	options: with two CP40

**coffee maker**

<b>CP 40:</b>	5 l	700 W – 30,0 A
---------------	-----	----------------

<b>water heater:</b>	5 l	600 W – 25,0 A
----------------------	-----	----------------

<b>sausage cooker:</b>	8,5 l	500 W – 21,0 A
------------------------	-------	----------------

<b>voltage:</b>	24 V DC
-----------------	---------

<b>weight:</b>	49 kg
----------------	-------

<b>casing:</b>	Foamed with PU integral, semi-hard foam, fine grained, work flap and front flaps with ABS and lock
----------------	--

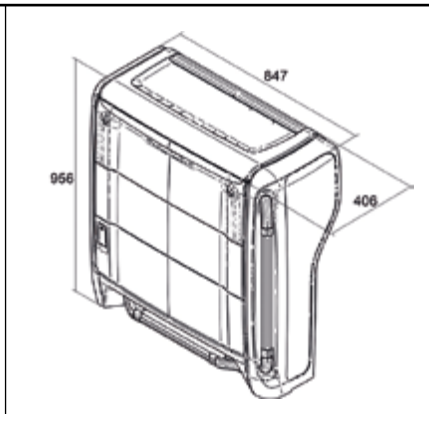

### QS MultiPlus NEOPLAN

**order no.:**

05.7090.00.00	
05.7091.00.00	options: with vacuum jup
05.6092.00.00	options: with two CP40

**coffee maker**

<b>CP 40:</b>	5 l	700 W – 30,0 A
---------------	-----	----------------

<b>water heater:</b>	5 l	600 W – 25,0 A
----------------------	-----	----------------

<b>sausage cooker:</b>	8,5 l	500 W – 21,0 A
------------------------	-------	----------------

<b>voltage:</b>	24 V DC
-----------------	---------

<b>weight:</b>	49 kg
----------------	-------

<b>casing:</b>	Foamed with PU integral, semi-hard foam, fine grained, work flap and front flaps with ABS and lock
----------------	--

**scope of delivery 05.6090.00.00 / 05.7090.00.00:**

- 5-liter CaféPerfect 40 coffee maker
- 5-liter VEK 6 water heater
- 8,5-liter WK 500 sausage cooker with overflow pipe
- touch panel for LED illumination function, thermostat, boiler filling and display for heating function and error messages, reset function to protect against overheating
- 2 drawers large, 2 drawers short
- drain basin
- water tap for filling the coffee maker
- rear side: 2 tables, luggage net

**options:**

Vehicle-specific installation kit on request

Additional extras for CaféPerfect under the accessories category.

## QS DUO 2G MCV

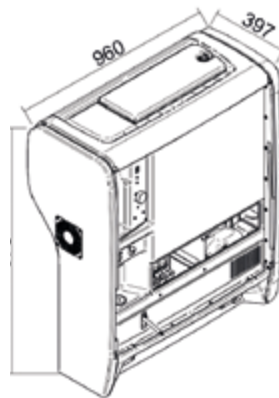

**order no.:**

05.9020.00.01

**cool box:** 52 l 60 W – 3 A

**water heater:** 5 l 600 W – 25 A

**voltage:** 24 V DC

**weight:** 65 kg

**casing:** Foamed with PU integral, semi-hard foam dark grey, fine grained, lockable cover optional

**options:**

Vehicle-specific installation kit on request

**scope of delivery:**

- 52 litre cool box, insulating PU foam with foam-fixed conveyor evaporator
- 5-litre water heater, insulating PU foam with mongrel fitting and discharge port, reset function to protect against overheating
- top loader, lockable cover
- control panel for thermostat, light in refrigerator, function indicator and fuse protection for electronics
- drain basin
- cup dispenser
- rear side: 2 tables, luggage net, ashtray optional





# On the way home



---

## **Accessories by TM**

We have a wide variety of accessories for you to choose from.  
We are happy to advise you – ask our specialists!

# Water supply

## Water supply 19 and 25 liter

For installation in QuickService onboard kitchens.

All fresh water supplies are already assembled and ready for connection.  
All water tanks are made of polyethylene, as well as being food-safe and resistant to pressure and impact.

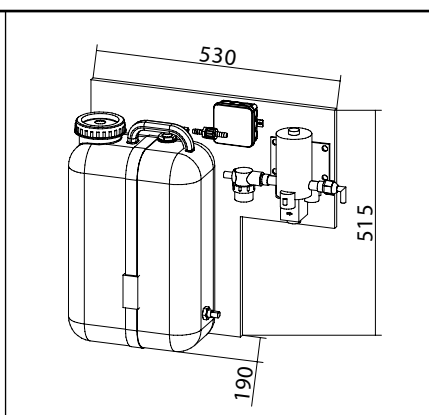

**scope of delivery:**

- 19-liter water tank, large cleaning opening  $\varnothing$  100 mm
- control relay with pre-fuse 5 A für pump
- swimmer switch

## Water supply for the MIDSIZE bus

**order no.:**

05.6011.12.00 (12 V)

**installation:** vertical

**volume:** 19 l

**voltage:** 12 V DC

**order no.:**

05.6011.00.00 (24 V)

**installation:** vertical

**volume:** 19 l

**voltage:** 24 V DC

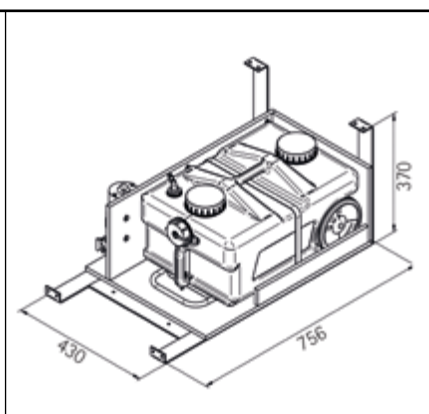
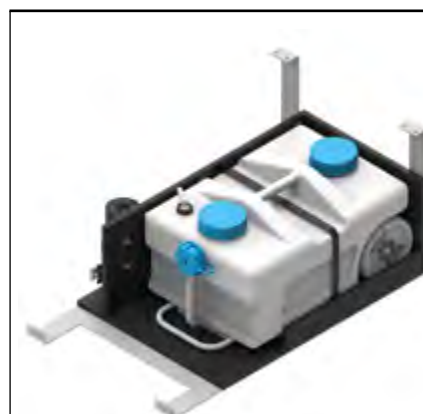

## tank horizontal

**order no.:**

16.6050.00.00

**installation:** hanging

**volume:** 25 l

**scope of delivery:**

- 25 l water tank, large cleaning opening  $\varnothing$  100 mm
- control relay with pre-fuse 5 A für pump

Protection of the devices (coffee maker, sausage cooker, water heater) is secured in the kitchen or is built in by the coach manufacturer.



## tank vertical

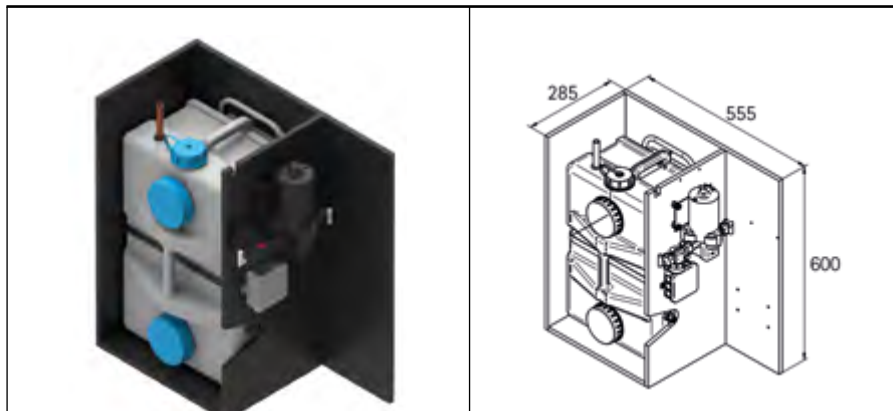

**order no.:**

16.6052.00.00

**installation:** vertical

**Volumen:** 25 l

**scope of delivery:**

- 25 l water tank, large cleaning opening  $\varnothing$  100 mm
- control relay with pre-fuse 5 A für pump

## tank vertical

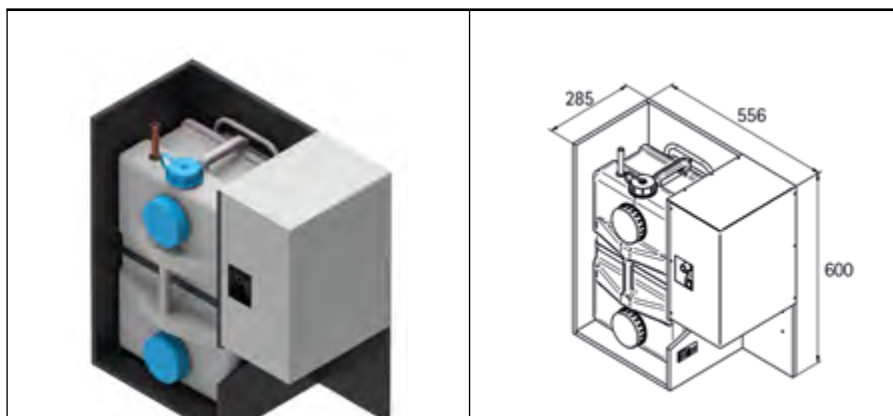

**order no.:**

16.6056.00.00

**installation:** vertical

**volume:** 25 l

**scope of delivery:**

- 25 l water tank, large cleaning opening  $\varnothing$  100 mm
- control relay with pre-fuse 5 A für pump

## Tank vertical

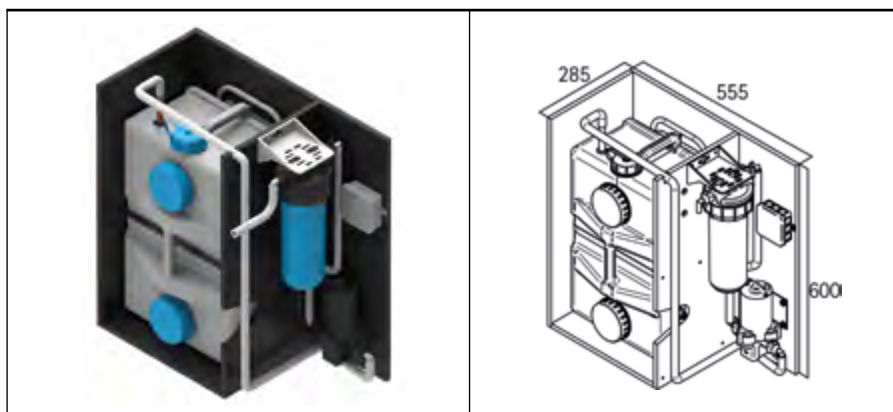

**order no.:**

16.6065.00.00

**installation:** vertical

**volume:** 25l

**scope of delivery:**

- 25 l water tank, large cleaning opening  $\varnothing$  100 mm
- control relay with pre-fuse 5 A für pump
- activated carbon filter

Protection of the devices (coffee maker, sausage cooker, water heater) is secured in the kitchen or is built in by the coach manufacturer.

# Water tanks

## Water tanks 19, 25 and 35 liter

Can be used separately or as a retrofit kit for fresh water supplies.

All water tanks are made of polyethylene, as well as being food-safe and resistant to pressure and impact.

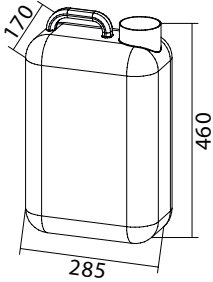
		<p><b>Water tank</b></p> <hr/> <p><b>order no.:</b> 05.6010.11.00</p> <hr/> <p><b>volume:</b> 19 l</p> <hr/> <p><b>scope of delivery:</b> - 19-liter water tank, large cleaning opening Ø 100 mm</p>
---	---	--

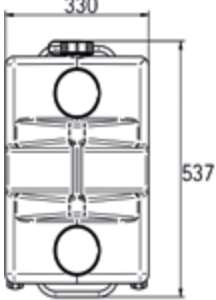
		<p><b>Mobile water tank</b></p> <hr/> <p><b>order no.:</b> 52.6050.00.03</p> <hr/> <p><b>volume:</b> 25 l</p> <hr/> <p><b>scope of delivery:</b> - 25-liter water tank, large cleaning opening Ø 100 mm and small opening, wheels, retractable handle</p>
---	---	---

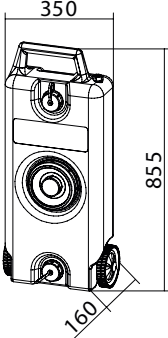
		<p><b>Mobile water tank grey</b></p> <hr/> <p><b>order no.:</b> 05.6000.00.01</p> <hr/> <p><b>volume:</b> 35 l</p> <hr/> <p><b>scope of delivery:</b> - 35-liter water tank, large cleaning opening Ø 100 mm and small opening, wheels</p>
---	---	--

## CaféPerfect

Proven coffee enjoyment with a new design.

CaféPerfect uses a percolator system. Heated water is led upwards through a stand-pipe to brew from top to bottom. Once the brewing process is complete, the machine automatically switches to heat-preservation mode. The filter is designed for medium-sized coffee grounds. For fine grind, we recommend using paper filters.

### CaféPerfect 40 model 2015



**scope of delivery:**

- 5-liter CaféPerfect 40
- filter tin, rising pipe
- cleaning brush

**order no.:**

- 10.5910.00.00 without remote contr., APD connector
- 10.5910.03.00 with remote contr., APD connector
- 10.5911.00.00 without remote contr., SB 50 connector
- 10.5911.03.00 with remote contr., SB 50 connector
- 10.5912.00.00 without remote contr., SB 50 connector retaining plate
- 10.5912.03.00 with remote contr., SB 50 connector retaining plate

<b>voltage:</b>	24 V DC
<b>power:</b>	700 W
<b>warm-keeping function</b>	65 W
<b>current consumption:</b>	30,0 A
<b>weight:</b>	3,4 kg
<b>volume:</b>	5 l
<b>volume cups 125 ml:</b>	40 cups
<b>time of brewing process 85°C:</b>	38 min.
<b>Electromagnetical Compatibility Norm ECE-R10</b>	

### CaféPerfect 20

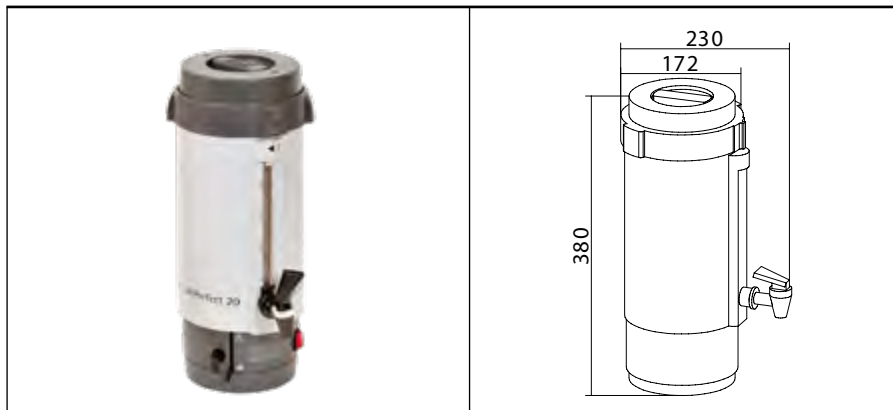

**scope of delivery:**

- 2,5-liter CaféPerfect 20
- filter tin, rising pipe
- cleaning brush

**order no.:**

- 10.5307.10.00 with remote control
- 10.5307.00.00 without remote control

<b>voltage:</b>	12 V DC
<b>power:</b>	400 W
<b>warm-keeping function:</b>	45 W
<b>current consumption:</b>	35,0 A
<b>weight:</b>	2,3 kg
<b>volume:</b>	2,5 l
<b>volume cups 125 ml:</b>	20 cups
<b>time of brewing process 85°C:</b>	50 min.
<b>Electromagnetical Compatibility Norm ECE-R10</b>	

**order no.:**

- 10.5306.10.00 with remote control
- 10.5306.00.00 without remote control

<b>voltage:</b>	24 V DC
<b>power:</b>	500 W
<b>warm-keeping function:</b>	45 W
<b>current consumption:</b>	21,0 A
<b>weight:</b>	2,3 kg
<b>volume:</b>	2,5 l
<b>volume cups 125 ml:</b>	20 cups
<b>time of brewing process 85°C:</b>	25 min.
<b>Electromagnetical Compatibility Norm ECE-R10</b>	

## AquaTherm

The simplified CaféPerfect.

Same housing, new system. The difference between AquaTherm and CaféPerfect is not visible from the outside. Looking inside the AquaTherm, however, you will quickly see the difference. This version includes no filter insert or standpipe. This gives the CaféPerfect a completely new and varied mode of operation – comparable to that of a kettle.

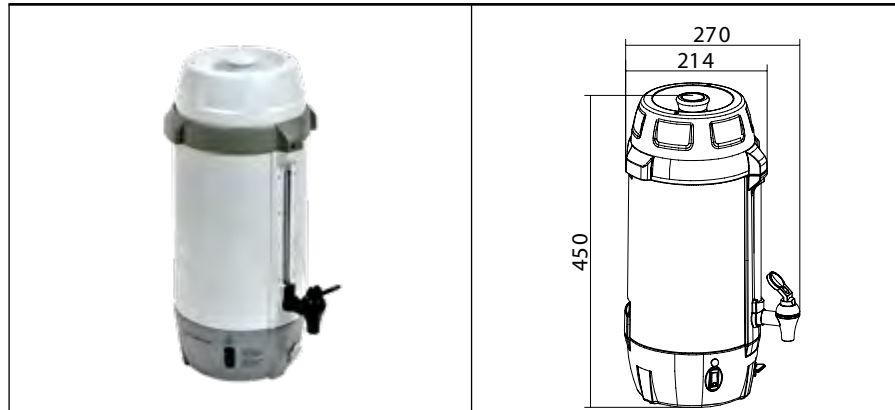

**scope of delivery:**

- 5-liter AquaTherm 40
- cleaning brush

### AquaTerm 40 model 2015

**order no.:**

- 10.5520.00.00 without remote contr., APD connector
- 10.5520.03.00 with remote contr., APD connector
- 10.5521.00.00 without remote contr., SB 50 connector
- 10.5521.03.00 with remote contr., SB 50 connector
- 10.5522.00.00 without remote contr., SB 50 connector
- 10.5522.03.00 with remote contr., SB 50 connector

<b>voltage:</b>	24 V DC
<b>power:</b>	700 W
<b>warm-keeping function:</b>	65 W
<b>current consumption:</b>	30,0 A
<b>weight:</b>	3,2 kg
<b>volume:</b>	5 l
<b>volume cups 125 ml:</b>	40 cups
<b>time of brewing process 85°C:</b>	38 min.

**Electromagnetical Compatibility Norm ECE-R10**

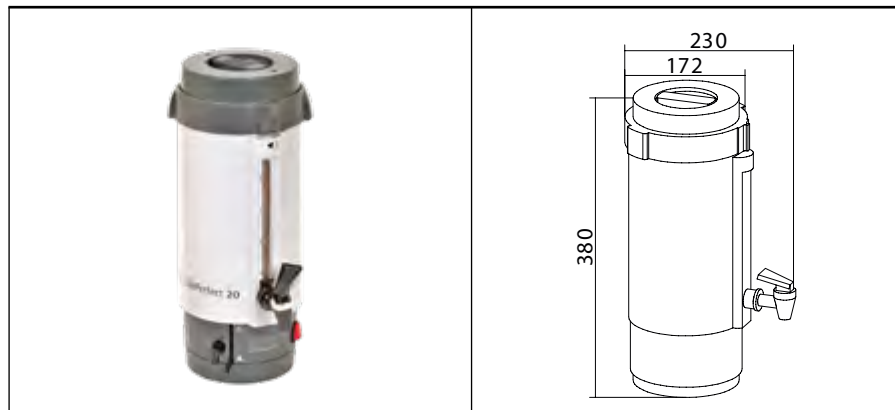

**scope of delivery:**

- 2,5-liter AquaTherm 20
- cleaning brush

### AquaTherm 20

**order no.:**

- 10.5310.12.00

<b>voltage:</b>	12 V DC
<b>power:</b>	400 W
<b>warm-keeping function:</b>	45 W
<b>current consumption:</b>	35,0 A
<b>weight:</b>	2,3 kg
<b>volume:</b>	2,5 l
<b>volume cups 125 ml:</b>	20 cups
<b>time of brewing process 85°C:</b>	50 min.

**Electromagnetical Compatibility Norm ECE-R10**

**order no.:**

- 10.5310.00.00

<b>voltage:</b>	24 V DC
<b>power:</b>	500 W
<b>warm-keeping function:</b>	45 W
<b>current consumption:</b>	21,0 A
<b>weight:</b>	2,3 kg
<b>volume:</b>	2,5 l
<b>volume cups 125 ml:</b>	20 cups
<b>time of brewing process 85°C:</b>	25 min.

**Electromagnetical Compatibility Norm ECE-R10**

## Holding device CaféPerfect 40

	<p><b>scope of delivery:</b></p> <ul style="list-style-type: none"> <li>- holding device for 5 l CaféPerfect 40 in anthracite plastic, right- or lefthand installation, with positioning for in and out</li> </ul> <p>Fits all CaféPerfect 40 and AquaTherm 40</p>	<p><b>order no.:</b></p> <hr/> <p>10.9900.00.00</p> <hr/>
---	--	---

## Holding device CaféPerfect 20

	<p><b>scope of delivery:</b></p> <ul style="list-style-type: none"> <li>- holding device 2,5 l CaféPerfect 20 in stainless steel, hanging installation, slewable, with snap lock</li> </ul> <p>Fits all CaféPerfect 40 and AquaTherm 40</p>	<p><b>order no.:</b></p> <hr/> <p>50.5306.00.10 (right version)</p> <hr/> <p>50.5306.00.20 (left version)</p> <hr/>
--	---	---

## Round filter

	<p><b>scope of delivery:</b></p> <ul style="list-style-type: none"> <li>- round filter for 5 l CaféPerfect 40 or 2,5-litre CaféPerfect 20</li> </ul> <p>Packages of 1000 pcs.</p>	<p><b>order no.:</b></p> <hr/> <p>10.9101.00.02 (CP 20)</p> <hr/> <p>10.9100.00.02 (CP 40)</p> <hr/>
---	---	--

## Vacuum jug

	<p><b>scope of delivery:</b></p> <ul style="list-style-type: none"> <li>- 1,3-liter vacuum jug, high-gloss black plastic, highly resistant inner coating, wide opening, screw cap</li> </ul>	<p><b>order no.:</b></p> <hr/> <p>05.2000.08.13</p> <hr/> <p><b>volume:</b> 1,3 l</p> <hr/>
---	--	---

## VEK 6 water heater

For the preparation of hot beverages.

The VEK6 5-liter water heater is used to boil water for hot beverages. The temperature of the boiler can be smoothly regulated (no fixed pre-set levels) via the temperature selector. This is turned off by turning the temperature selector back to level 0. A control lamp indicates the heating phase.

### Water heater VEK 6

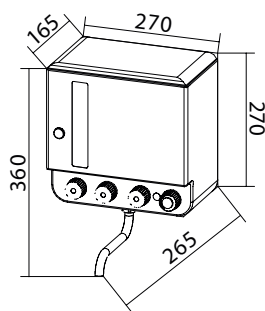

**order no.:**

07.6006.00.00

**voltage:** 24 V DC

**power:** 500 W

**current consumption:** 21,0 A

**weight:** 3 kg

**volume:** 5 l

**heating-up time:** 50 min.

**Electromagnetical Compatibility**

**Norm 72/245/EWG**

**scope of delivery:**

- VEK 6 water heater
- overheat protection during the dry operation / without water
- Temperature with manual reset – reset, thermal protection against excessive power supply
- temperature limiter at 110°C, spark absorber
- optional: anti-chalk fluid opening, with relais winter filling in the lid

## TWK water cooler

Freshly cooled water at any time.

The TWK water cooler consists of a fully-hermetic SECOP BD 80 F compressor. Exceptional operational safety is guaranteed by a fully-hermetic cooling unit. Durability ensured by wear-free components.

### TWK water cooler

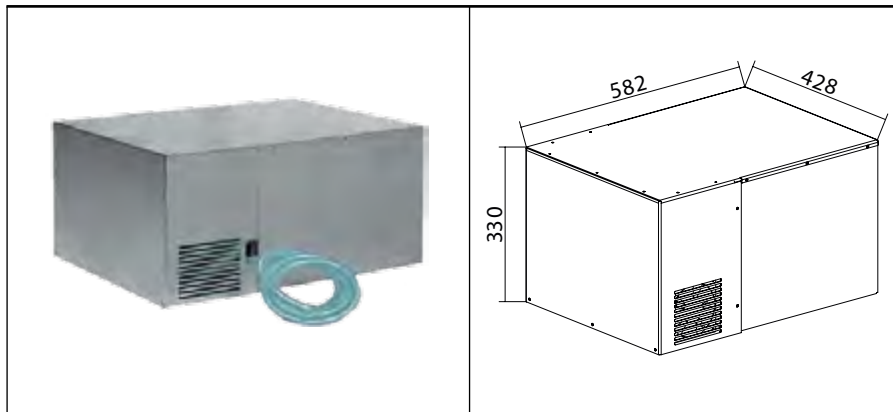

<b>order no.:</b>	
02.0200.00.00	
<b>voltage:</b>	24 V DC
<b>power:</b>	190 W
<b>current consumption:</b>	8,0 A
<b>weight:</b>	26 kg
<b>volume:</b>	15 l
<b>cooling-down time from +25°C to +5°C</b>	60 min.



**scope of delivery:**

- TWK water cooler
- cooling unit: compressor Secop BD 80 F, control of thermostat, Shurflo-pump, water filter, stainless steel water tank, PU-foam insulated, volumetric control by manometric switch

## Sausage cooker

For hot meals while on the go.

Stainless steel container with cover and heat-resistant silicone seal. Outlet with stainless steel overflow. Heating soldered on the underside of the container for optimal heat utilisation, protected via a discharge plate. Protected against overheating when being used dry/without water at 110°C, manual operation via the reset button. Thermal cut-off in case of excessive power supply. Switches off at 154°C.

### control panel

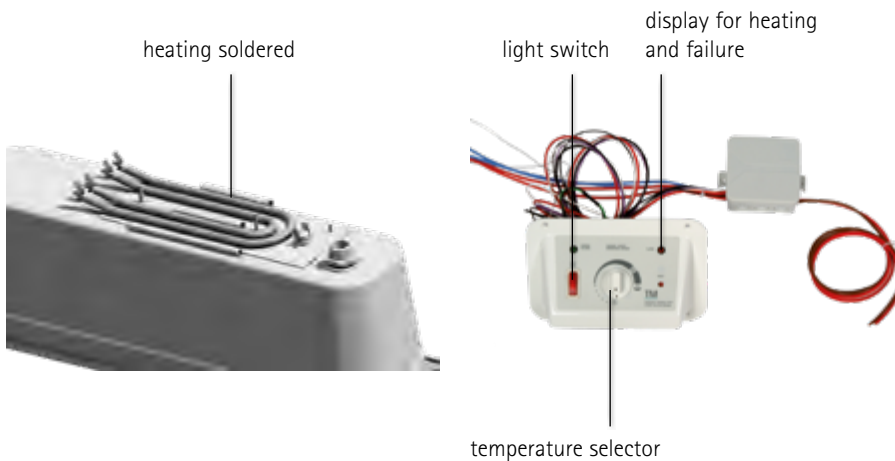

### WK 131 sausage cooker

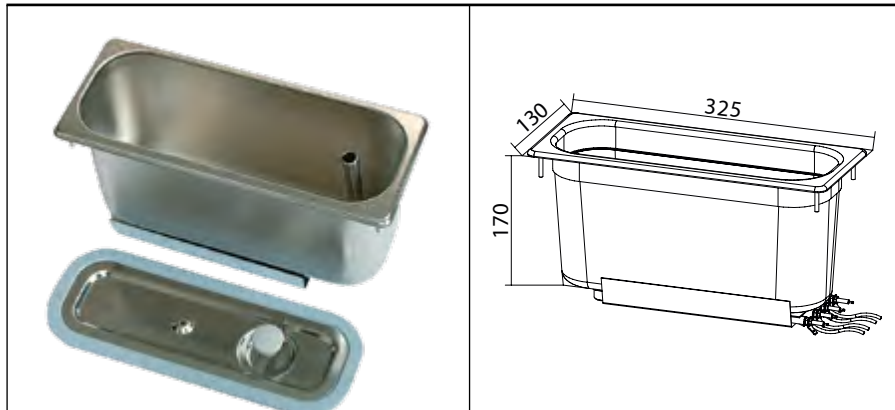

<b>order no.:</b>	08.0131.00.00	capacity for approx. 30 sausages
<b>voltage:</b>	24 V DC	
<b>power:</b>	500 W	
<b>current consumption:</b>	21,0 A	
<b>weight:</b>	2,5 kg	
<b>volume:</b>	3 l	
<b>drain pipe:</b>	3/4"	
<b>cable diameter:</b>	4 mm <sup>2</sup>	
<b>Electromagnetical Compatibility</b>		
Norm 72/245/EWG		

#### scope of delivery:

- WK 131 sausage cooker
- lid
- overflow pipe
- control panel



## WK 181 sausage cooker



<b>order no.:</b>	08.0181.00.00	capacity for approx. 40 sausages
<b>voltage:</b>	24 V DC	
<b>power:</b>	500 W	
<b>current consumption:</b>	21,0 A	
<b>weight:</b>	2,7 kg	
<b>volume:</b>	5 l	
<b>drain pipe:</b>	3/4"	
<b>cable diameter:</b>	4 mm <sup>2</sup>	
<b>Electromagnetical Compatibility</b>		
<b>Norm 72/245/EWG</b>		

**scope of delivery:**

- WK 181 sausage cooker
- lid
- overflow pipe
- control panel

## WK 500 sausage cooker

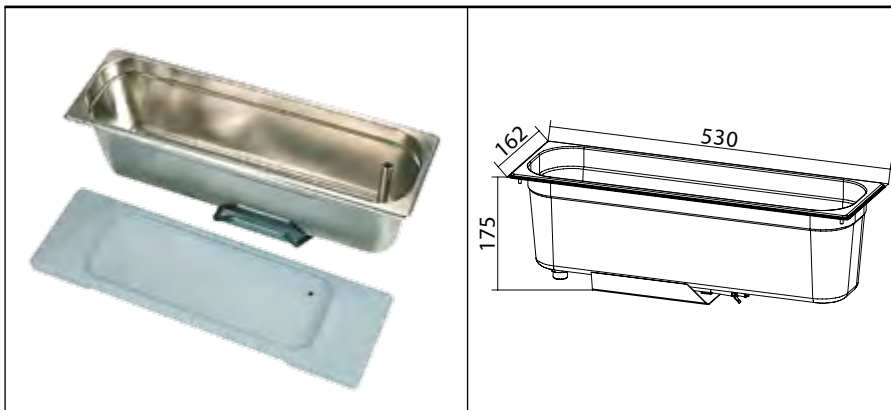

<b>order no.:</b>	08.0500.00.00	capacity for approx. 60 sausages
<b>voltage:</b>	24 V DC	
<b>power:</b>	500 W	
<b>current consumption:</b>	21,0 A	
<b>weight:</b>	3 kg	
<b>volume:</b>	8,5 l	
<b>drain pipe:</b>	3/4"	
<b>cable diameter:</b>	4 mm <sup>2</sup>	
<b>Electromagnetical Compatibility</b>		
<b>Norm 72/245/EWG</b>		

**scope of delivery:**

- WK 500 sausage cooker
- lid
- overflow pipe
- control panel

## Hygiene dispensers

Before preparing meals and drinks for even more hygiene contribute.

Suitable for commercially available 100 ml hand sanitizer bottles.

### Hygiene dispensers

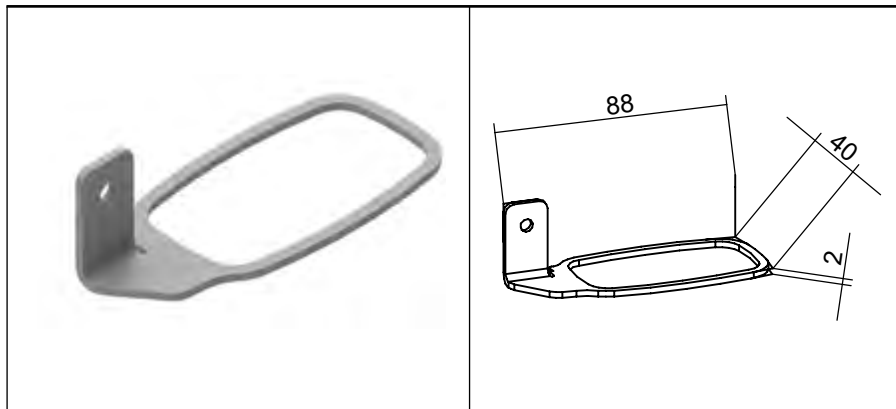

**order no.:**

50.3090.10.53

### hands disinfectants



**order no.:**

89.3090.10.00

volume: 100 ml

Example in QS MultiPlus 2G:



## USB Ports

Charge your phone or tablet comfortably.

Optional, the latest kitchen QS MultiPlus 2G design with the USB charging ports be equipped. The charging ports are located on the back of the galley, left and right side next to the tables.

### USB Ports

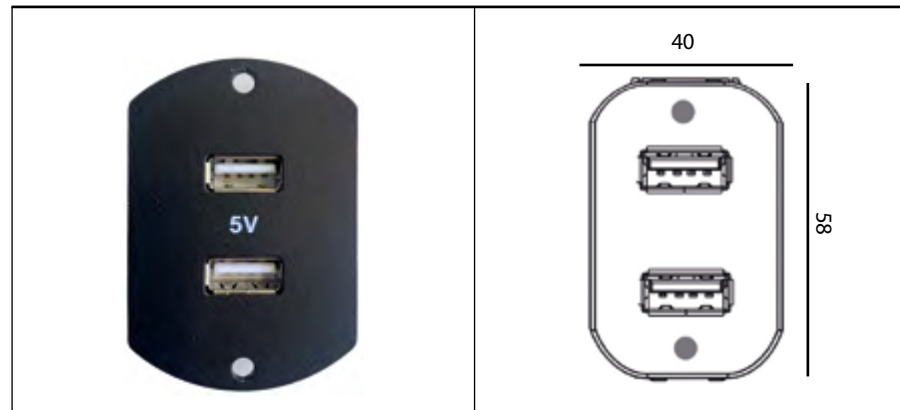

<b>voltage:</b>	5 V
<b>current consump.</b>	2,5 A
<b>certification:</b>	E-24 10R-041054

Example in QS MultiPlus 2G:



# cleaning supplies

## Cleaner for coffee machines

Cleaner for CaféPerfect and AquaTherm.

Fast coffee removal, especially brewing approach to filters and hard to reach places.

### Cleaner for coffee machines can



**order no.:**

89.5910.10.00

volume: 1 Kg.

### Cleaner for coffee machines box



**order no.:**

89.5910.10.01

volume: 10 Gr.

### Cleaner for coffee machines liquid



**order no.:**

89.5910.10.02

volume: 0,9 Liter

## Descaling agent for coffee machines

Descaling agent for CaféPerfect and AquaTherm.

Suitable for coffee machines and kettles.

Lime, mineral incrustations and scale are dissolved quickly.

### Descaling agent for coffee machines can



order no.:

89.5910.10.03

volume: 1 Kg.

### Descaling agent for coffee machines box



order no.:

89.5910.10.04

volume: 50 Gr.



1. Dashboard integrated cool box
2. QS Multiplus 2 G Kitchen
3. Transporter cool box
4. Summertime 2
5. Cool box KBU60
6. Central access toilet

# TM Product landscape



4

5

6

## **TM Technischer Gerätebau GmbH**

Böttgerstraße 13  
89231 Neu-Ulm  
Germany

phone +49 (0) 731/9 74 21-0  
fax +49 (0) 731/9 74 21-69  
e-mail [vm@tmtech.de](mailto:vm@tmtech.de)  
homepage [www.tmtech.de](http://www.tmtech.de)

## **Contact TM Germany sales and distribution national**

spare parts +49 (0) 731/9 74 21-53  
order transaction  
manufacturer +49 (0) 731/9 74 21-57  
customer service +49 (0) 731/9 74 21-41  
fax +49 (0) 731/9 74 21-69

## **TM Teknik Otomotiv**

**Ekipmanları İthalat İhracat Sanayi ve Ticaret Ltd. Şti.**  
**Gebze Organize Sanayi Bölgesi (GOSB)**

1000.Cadde, No: 1009  
41435, Çayırova, Kocaeli  
Turkey

phone +90 (0) 262/ 677 11-52  
fax +90 (0) 262/ 677 11-54  
e-mail [info@tmtech.com.tr](mailto:info@tmtech.com.tr)  
homepage [www.tmtech.com.tr](http://www.tmtech.com.tr)

## **Jincen-TM**

**Automotive Component Manufacturing Ltd.**

Industrial Zone Shuangfeng Road  
Hefei 23113  
P.R. China  
homepage [www.jincen-tm.com](http://www.jincen-tm.com)

## **Our company is ISO 9001 certified.**

Our products are tested according to the following standards:  
Burning behavior according to ECE R118.  
Electromagnetic compatibility according to ECE R10.  
Energy absorption test according to ECE R21.  
Bus comfort according to RAL-GZ 791.